







## Enhancing food safety and quality through high-pressure processing and PEF technologies: Comparative analysis

Baibaturov T. Abelbaevich<sup>1\*</sup>, Moldakhmetova Zamzagul<sup>2</sup>, Muldabekova B. Zhaksylykovna<sup>3</sup>, Alashbayeva L. Zhanabayevna<sup>4</sup>, Tursunbayeva Sholpan<sup>3</sup>, Yerzhigitov Yerkin<sup>5</sup>, Borankulova A. Sarsenbayevna<sup>4</sup>

1. Zhangir Khan West-Kazakhstan Agrarian Technical University, Uralsk, 090009, West Kazakhstan, KZ
2. Department of «Food Security and Biotechnology», NAO «Kostanay Regional University named after Akhmet Baitursynuly», 110005, Republic of Kazakhstan, Kostanay
3. Department of Technology of Bakery Products and Processing Industries, JSC "Almaty Technological University", 050061, Republic of Kazakhstan
4. Department of Food Production and Biotechnology, Taraz Regional University named after M.H. Dulati, 080000, Republic of Kazakhstan, Zhambyl Region, Taraz, St. Tole bi 60
5. Department of Energy Saving and Automation Kazakh National Agrarian Research University, Almaty, Abaya 8 St., Republic of Kazakhstan

\* Corresponding author's Email: [torebek-18@mail.ru](mailto:torebek-18@mail.ru)

### ABSTRACT

The increase in demand for energy consumption and the continuous reduction of its resources in the world reveal the necessity of optimizing and saving energy consumption. Since the use of traditional extraction methods in the country is associated with high consumption of water and energy, the use of pulsed electric field (PEF) technology as a non-thermal and environmentally friendly method has received attention recently. The main method of PEF for treating biological tissues is due to its use as non-thermal. Increasing cell permeability is applicable in extracting complex organic molecules. In this study, the PEF method is introduced as a gentle (non-thermal) processing approach to open the cellular structure in enhancing the quality and safety of food and compares it with traditional and thermal methods. The results of the comparison exhibited that the amount of energy consumed in the thermal method is 722 times that of the pulse method, while the PEF uses short-term high voltage pulses to open the cell structure by a process called electroporation. Extraction efficiency is considered as a function of electric field power, time and applied pulses amounts, temperature, and pulse frequency of the generator. Using the PEF method compared to the thermal one significantly reduces the energy consumption and can improve the quality and durability of the ingredients up to 20% depending on the type of product.

**Key words:** Pulsed field, Energy consumption, Food improvement, Shelf life.

**Article type:** Review article.

### INTRODUCTION

The strong PEF is one of the new technologies for creating long-term shelf life of food and medicine, which is considered as one of the non-thermal methods. Applying high voltage pulses between two electrodes with the aim of microbial inactivation was proposed at the beginning of the 21<sup>st</sup> decade and eventually led to the development of a process called electrohydraulic treatment (Yildiz *et al.* 2021). By applying high voltage pulses, sparks were created, sudden pressure waves (3 fast) up to 251 megapascals and ultraviolet light pulses were formed. Electrochemical reactions, sudden waves, ultraviolet light, a large number of reactive radicals were the reason for the antibacterial effects, however, the destroying of food particles and electrodes prevent its extend in food

industry (Pallarés *et al.* 2021). PEF is an emerging approach that is employed to process cells using short pulses of a strong PEF. The external usage of PEF to the cells leads to the formation of pores in the membrane of plant cells and facilitates the release of cell contents such as phenolic components. The conducted experiments show that PEF treatments can be used to break cells in food and their application was extended to the inactivation of microorganisms and wastewater treatment. The use of electric fields for the electro plasmolysis of sab slices was reported for the first time, in which an 11-12% increase in juice yield was obtained and products with a lighter color and less oxidation were obtained compared to the products of heat and enzyme treatments (Shariati *et al.* 2013). Given the impact of PEF on the quality of sacrificial materials, many researches have been performed. In his research, Asadipour *et al.* (2005) reported that less flavor degradation occurred in milk treated with PEFs suggesting the possibility of producing dairy products such as cheese, butter and ice cream using milk treated with PEF, although detailed and complete information was not provided in the report. Cao *et al.* (2020) and Forte *et al.* (2023) performed some researches on the shelf life, physicochemical features and sensory attributes of milk with 2% fat treated by a PEF with a 40 kV power and 6-7 pulses. No physical, chemical or sensory changes were observed after this treatment compared to a simple sample treated with thermal pasteurization. The researchers did not observe any effect of the destruction of vitamins by the pulse treatment. Grosu *et al.* (2021) investigated the color change, pH, proteins, moisture and particle size of UHT plasma milk exposed to PEF treatment. They did not reported any difference in terms of the investigated parameters (color, pH, protein, moisture, and particle size) before and after the treatment. The data of Buitimea Cantúa *et al.* (2022) showed that using PEF with an intensity of 30 kV/cm along with a temperature of 50 °C can results in a coagulation effect similar to thermal pasteurization. Therefore, for the production of cheese, the temperature of the treatment in higher electric intensity (30 kV/cm) and longer pulses (120 pulses) to form the desired and desirable clot should not exceed 50 °C. Giannoglou *et al.* (2021) evaluated the impact of PEF on dairy to the polarization of the protein molecule, the separation of protein subunits with non-covalent bonds in the fourth structure, and the change in protein composition, resulting in exposure to the reaction of sulfhydryl groups or hydrophobic amino acids. If the duration of the electrical pulse is long enough, hydrophobic interactions or covalent bonds will occur and agglomerates will form. The increase in consumer demand for fresh and safe products has created limitations in choosing the type of food processing technology. The use of PEF high electric field pulse in food processing is focused on two main areas, i.e., microbial inactivation and liquid food protection, as well as increasing mass and tissue transfer in solids and liquids. The mechanisms of microbial inactivation include transpiration potential, electromechanical compression and osmotic imbalance. The effective factors of PEF are: electric field intensity, time and frequency processing, pulse shape and polarization, as well as processing temperature. Among the benefits of PEF are: deactivation of microbes at low temperature without damaging the texture of food, maintaining high nutritional value, increasing shelf life, preventing harmful changes in sensory and physical properties of food, as well as reducing drying time. The mechanism of the effect of PEFs on plant cells is based on creating a hole due to electric currents and increasing the permeability and then enhancing the mass transfer rate in the membrane, which can be used in three important processes of the food industry, including the following:

- Destruction of microorganisms as well as application of pasteurization and sterilization processes without applying heat.
- Drying and reducing water in food
- The processes of extracting intracellular substances from plant and animal tissues

The use of this non-thermal technology provides a possibility to produce healthy products with a relatively low level of processing while maintaining sensory quality and nutritional properties.

## **MATERIALS AND METHODS**

One of the non-thermal techniques of food preservation is the use of PEFs, which are used to inactivate microorganisms in such a way as to cause the least damage to the quality properties of food. Increasing consumer demand for higher quality products with minimal loss of nutrients compared to conventional thermal methods increased the use of non-thermal ones, including the application of PEFs. The reason for using this process can be attributed to the research that was performed in Germany.

### **Different parts of the system**

The PEF process systems are made up of 1 main level, which includes a high voltage power supply, a capacitor for energy storage, a process reactor, a pump to drive food into the reactor, cooling equipment, measuring tools

(voltage, current and temperature) and the data logger is used to control and record information. A schematic of PEF system is shown in Fig. 1.

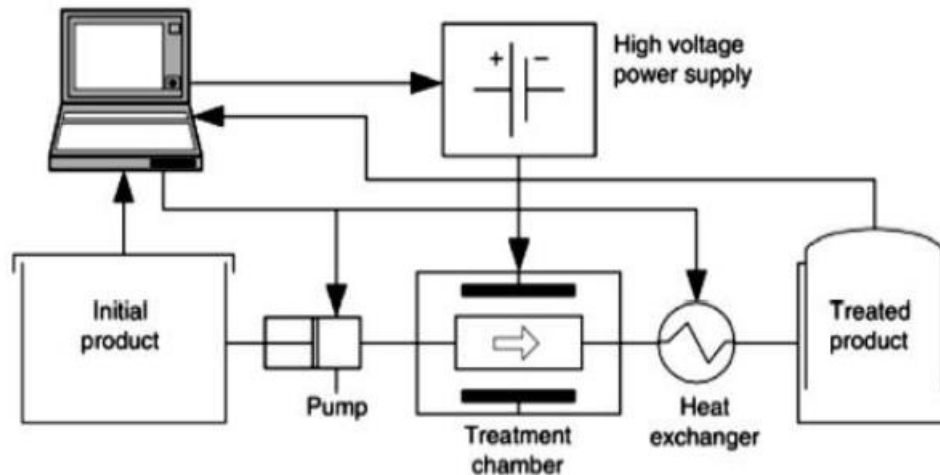

Fig. 1. Schematic of the equipment used in the process of PEFs.

### Pulse electric field treatment

PEF treatment is a mild (non-thermal) processing method to open the cellular structure of plants, the main interest of which is the treatment of biological tissues. The findings show that the conditions used over the treatment increase the temperature by more than 10 °C. This limited temperature increase, leads to valid evidence of PEF processing as a non-thermal approach that is applied in the conditions used (Yildiz *et al.* 2021). In general, the set of PEF treatment operations, which are performed with high voltage and short-term pulses to open the cellular structure of the plant, is called electroporation process 2. More precisely, when the potential difference reaches a critical level, the attraction force between charges with opposite poles causes the electric pressure force to prevail over the membrane's elastic force, so that, pores are formed in the membrane, which causes this phenomenon referred to electroporation. The created pores are reversible if they are small compared to the surface of the membrane, otherwise they are irreversible. A pulse generator device with a voltage of 14 kV and frequency from 1 to 50 Hz provides rectangular pulses for experiments (Zulkurnain *et al.* 2021). The samples are located in the filter chamber of two stainless steel electrodes filled with distilled water solution. The shorter the distance between two series of pulses (pause between pulses), the less powerful electric field we need to tear the cell membrane. However, the longer the pulses are created with the relaxation time, the higher the electric field is needed to achieve high efficiency. PEF technology is mostly used for liquid, homogeneous and low-viscosity foods. Those materials that are sensitive to dielectric breakdown are not suitable for processing in the electric field. This system is not suitable for processing foods with foam. Also, in the PEF, there is a possibility of the phenomenon of dielectric breakdown (Katsimichas *et al.* 2023). The technology of PEFs has more advantages than the use of conventional thermal processes in food, which, in addition to the destruction of microorganisms, can be mentioned to preserve the original color, flavor, texture and nutritional value of food. In addition, preserving the consistency and cell structure (given that this process only affects the cell wall, unlike thermal methods that damage the whole) as well as increasing the speed and efficiency of extraction are other advantages of this process. Activating microorganisms in milk, milk products, eggs, water and other foods. The application of this process is limited to foods that are free of air bubbles and by less electrical conductivity. Therefore, sugar beet can also be used in sugar extraction. This process can be used in the production of fruit juices such as orange juice or apple juice. Zhang *et al.* (2022) conducted several researches in order to industrialize this process, in order to improve the aroma, taste and functional characteristics, texture as well as higher useful life of the products treated with this process. Recently, the process of PEF is used in drying processes, modification of enzyme activity, and preservation of nutrients in solid and semi-solid foods, wastewater treatment (Fam *et al.* 2021).

### Limitation of PEF

PEF technology is mostly used for liquid, homogenous foods without suspended substances and with low viscosity, and it is used less for foods containing particles and suspended substances. Liquid foods are considered conductors of electric current due to their high concentrations of electrically charged ions. In addition, the presence

of air bubbles and suspended particles cause a severe drop in field efficiency due to their dielectric properties different from the liquid part of food. As the dielectric strength of the gas bubbles increases, a partial discharge occurs inside the bubbles, which evaporates the liquid and produces more steam, accompanying by the expansion of the bubbles. The foods sensitive to dielectric breakdown are not suitable for processing in the electric field system. In addition, this system is not suitable for processing foods containing foam (due to the sensitivity of air bubbles to dielectric breakdown). Moreover, there is a possibility of dielectric breakdown in this method.

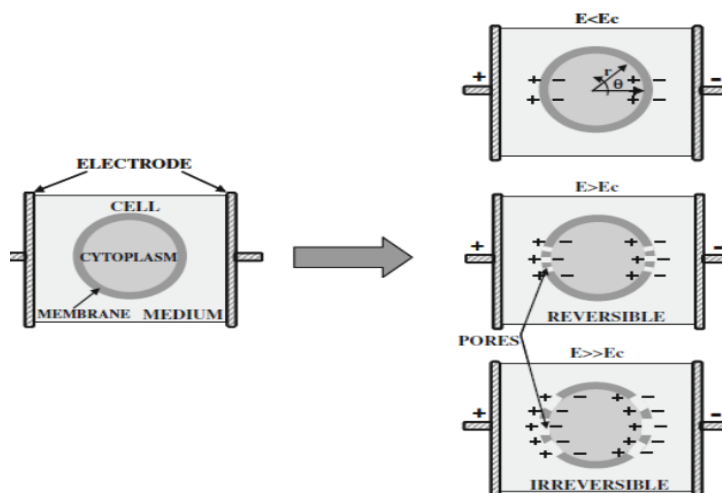

Fig. 2. Pores creation in the cell membrane under PEFs.

## RESULTS

Electric fields are applicable in the food industry. Their most important application, in addition to deactivating undesirable microorganisms and enzymes, include reducing free fatty acids during food storage, improving its organoleptic and textural properties, improving and accelerating process of removal of clogging on membranes and finally increasing the shelf life of manufactured products.

### Drying Process

One of the oldest and at the same time the most widespread processes used to preserve food against spoilage is the drying of products. The main goal in drying agricultural products is to reduce the humidity to such an extent that they can be kept for a long time, to increase the shelf life of the product by reducing the microbial and enzymatic activities and reducing the speed of chemical reactions. Drying by hot air methods is a process in which mass and heat transfer are simultaneous, while phase change also occurs in this process. It is one of the most common methods for food preservation, and also reduces water activity, prevents the growth of microorganisms, minimizes destructive reactions, and as a result increases the shelf life of food. In the dryer with hot air, because the thermal conductivity is low, a longer period of time is required for drying. Especially for the reason that during the period, the drying speed and energy efficiency decrease. This is mostly due to the rapid decrease in heat transfer levels and subsequent shrinkage, which ultimately leads to a decrease in moisture transfer levels and sometimes also a drop in heat transfer levels. To solve this problem and achieve a higher quality product, combined methods with hot air such as PEF is employed. Drying with the help of a PEF is a method that is widely used to disrupt plant cells. This method causes cell walls to break and collapse, and large cavities and intercellular spaces are formed. As a result, it allows cell materials to be easily extracted. However, the conventional thermal water extraction method is time and energy intensive. In addition, drying may reduce the biological activities of thermally unstable components. For intracellular components, material migration, aqueous solvent and organic material extraction are the primary methods

### Application of PEF in osmotic water extraction

Osmotic dehydration is the process of extracting water based on the placement of food in a hypertonic solution. In a research (Brito & Silva 2024) the composition of the osmotic water extraction process for carrot pieces with a thickness of 0.5 cm at 60 °C and at intervals of 120 minutes (6 intervals of 20 minutes), and 180 minutes (6 intervals of 30 minutes) in different concentrations of sucrose and glucose as well as their mixture at 3 levels of 20, 30 and 40% in a static state at 25 °C were examined. The ratio of osmotic solution to fruit was selected at 5:1.

The results showed that the amount of water removal, as well as absorption of solids and weight loss are directly related to the elevation in concentration and exposure time of ultrasound. The glucose osmotic solution exhibited the highest amount of water excretion and sugar absorption, while the sucrose one the lowest amount of water excretion. Also, osmotic solutions containing both sucrose and glucose displayed sugar absorption and water excretion between glucose and sucrose solutions alone. In addition, their results showed that using ultrasound increases the amount of water removal, sugar absorption and weight loss compared to the samples without ultrasound treatment. The pre-process of the PEF has been effective in improving the performance of water removal and solid absorption in the osmotic water removal process during the studies carried out by Morales De la Peña *et al.* (2021).

### **The application of PEF in increasing the preservation and shelf life of food**

One of the most innovative and newest technologies in the processing of heat-sensitive products, especially milk, is the use of PEFs. This process is performed at low temperatures, so less heat reaches the milk, hence its sensory properties and nutritional quality are preserved. In addition, by the destruction of harmful microorganisms and undesirable enzymes, the shelf life of milk is elevated and it exhibits the least harmful effect on the nutritional and vitamin value of milk. Some researchers have conducted studies related to the effect of PEFs on the chemical and physical characteristics of dairy products, some of them were mentioned in the introduction of this chapter. During an experiment, fresh apple juice and reconstituted apple juice were processed from the concentrate by this method. The storage life of apple juice processed with PEF at 4 °C was three to four weeks. The concentration of total solids was 11%, of which 10% was carbohydrates, 0.2% ash, and a small amount fats and proteins. The pH was the same before and after the electric field treatment. In these experiments, the electric field had no special effect on the concentration of vitamin C. In this sensory evaluation test, there was no significant difference between treated and untreated apple juice (Morales De la Peña *et al.* 2021).

### **Application of PEF in extraction of intracellular substances**

This technique can be used as a pre-processing step in the extraction of substances with cellular value such as enzymes, sugars and other compounds in the fruit juice production process. In addition, processing with this method improves the extraction of fruit juice and elevates the degree of purity.

### **Effect of PEF on foods**

Nowadays, the PEF method is widely used in various sectors of the food industry due to its many applications. Finally, this method also leaves various effects on food components, which we will examine a number of them as follows (Islas Moreno *et al.* 2023):

#### **Effect of PEF on proteins**

The protein against to PEF shows some phenomena that depend on the PEF process and its features such as pulse duration, field strength, number of pulses, frequency, etc. Also on the type and concentration of the protein. But in general, the PEF, can make the following changes on proteins in food:

- Breaking the disulfide bond.
- Exposure to hydrophobic amino acid residues.
- Unfolding of the second and third structures.
- Increasing the solubility of proteins. λIncreasing compaction and spontaneous accumulation of proteins.

It seems that balanced conditions do not have much effect on the physico-chemical properties of proteins. For this type of treatments, parts of the proteins are opened and dissociation occurs in the subunits, the result of which is an increase in solubility. With more intense treatments, the above phenomenon will happen and as a result solubility or accumulation will occur. The most common reaction between proteins resulting from severe PEF conditions includes the following three:

- Polymerization; Aggregation caused by non-covalent interactions (such as electrostatic, hydrogen bonds and hydrophobic interactions); and Disulfide bonds.

#### **Effect of PEF on lipids**

The use of electric pulse field in food industries can be effective on food components, one of which is lipids. Its effects on lipids can be summarized as follows:

- Creating electrochemical reactions and affecting the structure of lipids.
- Strengthening its interaction with oxygen.

Possibility of forming hydrogen radicals.

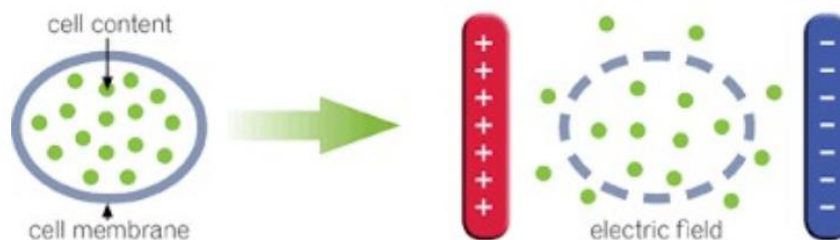

**Fig. 3.** Releasing intracellular substances under PEF.

### Comparing treatment effects on food quality

In general, in the conducted research, PEF treatment has been used to improve the performance of processes by reducing operating conditions (temperature, pressure, etc.) and as a result, reducing energy consumption and increasing product quality. However, reaching the values optimizing process factors is of great importance. In particular, the use of PEF in the osmotic water extraction process follows a complex process, and the comparative results as shown in Fig. 1, indicating that only higher field intensity and more pulses increase water removal and absorption. It will not result in solids. Extraction with the help of PEF has a significant extraction efficiency in a short period of time and energy consumption. In addition, compared to traditional methods, it elevates the drying speed and reduces the process time by maintaining the quality characteristics of the product such as color (Salehi 2020). As shown in Fig. 4, the most appropriate of non-thermal approaches is the application of PEF technology, which has received attention recently. In the proposed method, PEFs with high voltage and in a short time are used. The use of high voltage in these processes creates an electric field and causes changes in cells, whether plant- or microbial- cells. In this way, it affects microorganisms and by deactivating undesirable microorganisms and enzymes at low temperature and without damaging the food texture, it improves the organoleptic and textural properties of the products. It preserves the high nutritional value of the products and prevents harmful variations in the sensory and physical features of the food. Finally by upraising the shelf life of the products, it enables easier storage of the products (Huang *et al.* 2020; Atuonwu *et al.* 2020).

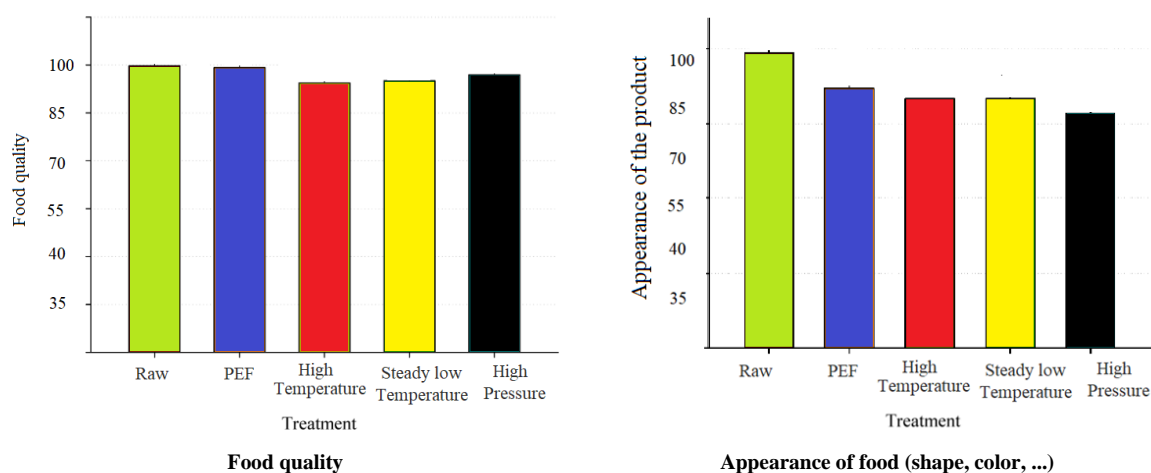

**Fig. 4.** Comparison of treatment effects on food process.

Using this method, by minimizing the number of processes on food, leads to the reduction of waste caused by long thermal processing and the reduction of fossil fuel pollution, subsequently, helps to preserve the environment. By regulating different treatment conditions, including the field intensity and the number of applied pulses, in order to enhance the ability to penetrate the cell and achieve the maximum degree of destruction while maintaining the consistency of the cell, it speeds up the extraction process and elevates the productivity with the least amount of energy consumption.

### CONCLUSION

The PEF is a non-thermal process in which food is exposed to a high-voltage pulsed field. While this method has little effect on the sensory characteristics and nutritional value of the products, it is able to destroy various

microorganisms with the main mechanism of membrane destruction, and in addition to the discussion of preserving food products, due to the increase in cell permeability as a precursor, the process increases the extraction efficiency of intracellular materials such as fruit juice, sugar, oil and also elevates the drying speed. In addition, improving the performance of rennet in milk during cheese making is one of its other uses. When the product is processed and pasteurized by thermal methods, it loses its quality properties, however, by employing the PEF method, in addition to reducing the microorganisms of the sample, its natural color and taste are also preserved. The most important results of this research are increasing the drying speed and reducing the process time by using PEF, in comparison with the traditional method while maintaining the quality characteristics of the product such as color.

## REFERENCES

- Asadipour, A, Mehrabani, M & Najafi, ML 2005, Volatile oil composition of *Centaurea aucheri* (DC.) Wagenitz. *DARU Journal of Pharmaceutical Sciences*, 13: 160-164.
- Atuonwu, JC, Leadley, C, Bosman, A & Tassou, SA 2020, High- pressure processing, microwave, ohmic, and conventional thermal pasteurization: Quality aspects and energy economics. *Journal of Food Process Engineering*, 43: e13328.
- Brito, IPC & Silva, EK 2024, PEF technology in vegetable and fruit juice processing: A review. *Food Research International*, 114207.
- Buitimea Cantúa, GV, Rico Alderete, IA, Rostro Alanís, MDJ, Welti Chanes, J, Escobedo-Avellaneda, ZJ & Soto Caballero, MC 2022, Effect of high hydrostatic pressure and PEFs processes on microbial safety and quality of black/red raspberry juice. *Foods*, 11: 2342.
- Cao, T, Lu, Y, Zhu, M, Cheng, J, Ye, B, Fang, N & Kazemi, E 2020, Effects of *Salvia miltiorrhiza* and *Radix astragali* on the TGF- $\beta$ /Smad/Wnt pathway and the pathological process of liver fibrosis in rats. *Cellular and Molecular Biology*, 66: 46-51.
- Fam, SN, Khosravi Darani, K, Massoud, R & Massoud, A 2021, High-pressure processing in food. *Biointerface Research in Applied Chemistry*, 11: 11553-11561.
- Forte, T, Figueiredo, E, Eusébio, C & Tibério, ML 2023, Produce or not produce certified foods? An exploratory analysis from Portugal, *Revista Iberoamericana de Viticultura Agroindustria y Ruralidad*, 10: 213-232, <https://doi.org/10.35588/rivar.v10i30.5842>
- Giannoglou, M, Dimitrakellis, P, Efthimiadou, A, Gogolides, E & Katsaros, G 2021, Comparative study on the effect of cold atmospheric plasma, ozonation, pulsed electromagnetic fields and high-pressure technologies on sea bream fillet quality indices and shelf life. *Food Engineering Reviews*, 13: 175-184.
- Grosu, V, Kholiavko, N, Zhavoronok, A, Zlati, ML & Cosmulese, CG 2021, Model of financial management conceptualization in Romanian agriculture. *Economic Annals-XXI*, 191: 54-66. DOI: <https://doi.org/10.21003/ea.V191-05>.
- Huang, HW, Hsu, CP & Wang, CY 2020, Healthy expectations of high hydrostatic pressure treatment in food processing industry. *Journal of Food and Drug Analysis*, 28: 1-13.
- Islas Moreno, A, Rodríguez Ortega, A & Aguirre Álvarez, G 2023, Business success in the agricultural, livestock and agro-industrial sectors: definitions issued by experts, *Revista Iberoamericana de Viticultura Agroindustria y Ruralidad*, 10: 269-281, <https://doi.org/10.35588/rivar.v10i30.5943>.
- Katsimichas, A, Dimopoulos, G, Dermesonlouoglou, E & Taoukis, P 2023, Modelling and Evaluation of the Effect of PEFs and High Pressure Processing Conditions on the Quality Parameters of Osmotically Dehydrated Tomatoes. *Applied Sciences*, 13: 11397.
- Morales De la Peña, M, Rábago Panduro, LM, Soliva Fortuny, R, Martín Belloso, O & Welti Chanes, J 2021, PEFs technology for healthy food products. *Food Engineering Reviews*, pp. 1-15.
- Pallarés, N, Berrada, H, Tolosa, J & Ferrer, E 2021, Effect of high hydrostatic pressure (HPP) and PEF (PEF) technologies on reduction of aflatoxins in fruit juices. *Lwt*, 142: 111000.
- Salehi, F 2020, Physico-chemical properties of fruit and vegetable juices as affected by PEF: A review. *International Journal of Food Properties*, 23: 1036-1050.
- Shariati, A, Azaribeni, A, Hajjigharamanzadeh, P & Loghmani, Z 2013, Liquid-liquid equilibria of systems containing sunflower oil, ethanol and water. *APCBEE procedia*, 5: 486-490.

- Yildiz, S, Pokhrel, PR, Unluturk, S & Barbosa Cánovas, GV 2021, Changes in quality characteristics of strawberry juice after equivalent high pressure, ultrasound, and PEFs processes. *Food Engineering Reviews*, 13: 601-612.
- Zhang, Z, Zhang, B, Yang, R, & Zhao, W 2022, Recent developments in the preservation of raw fresh food by PEF. *Food Reviews International*, 38: 247-265.
- Zulkurnain, M, Sulaiman, A, & Balasubramaniam, VM 2021, High-Pressure-Based Food-Processing Technologies for Food Safety and Quality. In *Food Processing*, pp. 1-26, CRC Press.

---

***Bibliographic information of this paper for citing:***

Abelbaevich, BT, Zamzagul, M, Zhaksylykovna, MB, Zhanabayevna, AL, Sholpan, T, Yerkin, Y, Sarsenbayevna, BA 2024, Enhancing food safety and quality through high-pressure processing and PEF technologies: Comparative analysis. *Caspian Journal of Environmental Sciences*, 22: 513-520.